

Honeywell

Honeywell Information Systems Italia

SPPL (MOS)

INSTALLATION

71011350 - 300





OCTOBER 1981

COPYRIGHT © 1981 HONEYWELL INFORMATION SYSTEMS ITALIA

The information contained herein, unless specified otherwise is the exclusive property of Honeywell Information Systems Italia and shall not be disclosed or reproduced in whole or in part without explicit written approval from the company.
Distribution of this material outside the company may occur only if authorized.

F.E. Headquarters - Via Nuvolone, 44 Milan
Printed in Italy
All Rights Reserved

RECORD OF REVISION

DATE	CHANGE N.	NOTES/PAGES AFFECTED	SIGNATURE
Rev. 0 6/1976		1st Edition cod. 71011350-001	
Rev. 0 4/1977		2nd Edition cod. 71011350-100	
Rev. 0 6/1979		3rd Edition cod. 71011350-200	
Rev. 0 10/1981		4th Edition cod. 71011350-300	

INDEX

Section	Page
VI INSTALLATION	6-1
6.1 Site Preparation	6-2
6.1.1 Physical Specifications	6-2
6.1.2 Electrical Specifications	6-2
6.1.3 Environmental Specification	6-3
6.1.4 SPPL Operator Panel Features	6-4
6.2 Physical installation	6-6
6.2.1 Required Material	6-6
6.2.2 Uncrating	6-6
6.2.3. Completeness Check-out	6-6
6.3 Unit installation	6-7
6.3.1 Required Material	6-7
6.3.2 Procedure installation	6-7
6.3.3 Keyboard Installation	6-12
6.3.4 "Vertical Paper Path" Paper Guide Installation	6-13
6.3.5 SPPL customization	6-13
6.3.6 POWER ON procedures	6-28
6.3.7 OFF-LINE Test procedure	6-29
6.3.8 Connection to host	6-30
6.3.9 ON-LINE Test procedures	6-30
6.3.10 Final operation	6-30
6.4 De-Installation	6-31
6.4.1 De-Installation Procedure	6-31

VI INSTALLATION

Purpose

This manual illustrates the sequence of operations that must be performed to correctly install the SERIAL PRINTER PRODUCT LINE.



All dangerous voltage (≥ 42 V pp), high temperature points and areas containing parts in movement are conveniently protected and indicated by protection labels.

When operating without protection covers be very careful and, after executing all operations, restore the protection covers and the possible ground connections which have been previously removed, as at the start.

On the SPPL's the protection on the network voltage input is implemented by interrupting only the phase. For this purpose, a polarized plug which must coincide with a same type outlet available at the customer site, is mounted on the power cable.

It is strictly mandatory to comply with the polarities on the network power outlet.

An external label is stuck near the main breaker to warn the technical personnel.

The unit is not foreseen to be installed on IT type networks (neutral isolated).

6.1 SITE PREPARATION

6.1.1. PHYSICAL SPECIFICATIONS

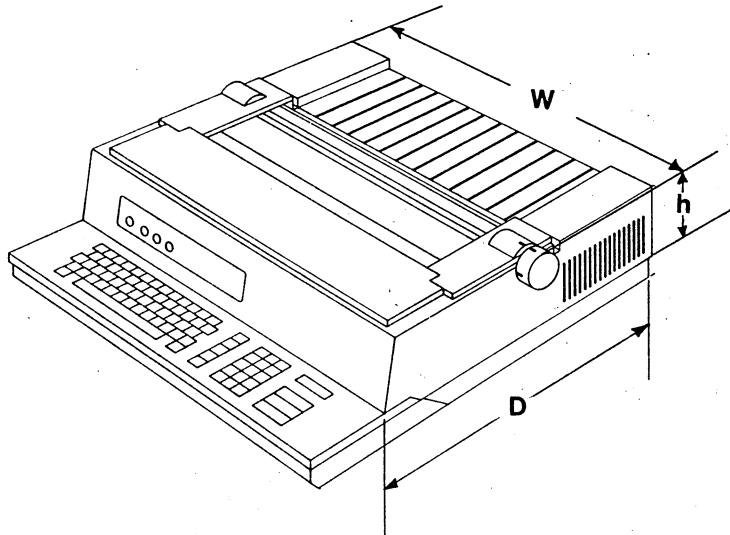

Fig. 6.1

WIDTH (W)
 DEPTH (D)
 HEIGHT (h)
 WEIGHT

WITHOUT KEYBOARD	WITH KEYBOARD
MARA 570 mm 22.5"	MARA 570 mm 22.5"
MINA 590mm 23.2"	MINA 590mm 23.2"
MARA 500 mm 19.7"	MARA 640 mm 25.2"
MINA 520mm 20.5"	MINA 660mm 26"
MARA 185 mm 7.3"	MARA 185 mm 7.3"
MINA 185mm 7.3"	MINA 185mm 7.3"
26 Kg	29 Kg

6.1.2. Electrical Specifications

VOLTAGE (V)	Hz	TOLERANCE	MAX POWER DRAWN (VA)	N. OF PHASES (AC)
208/AC	60	177 to 228 V	270	1 + N + GND
120 AC	60	102 to 132 V	270	1 + N + GND
220/240 AC	50	187 to 264 V	270	1 + N + GND
120 AC	50	102 to 132 V	270	1 + N + GND

6.1.3. Environmental Specifications

Temperature	Range 10 to 38°C/50.0 to 100.4 °F
	Gradient 11°C/51.8°F per hour
Relative Humidity	Range 30 - 70% RH
Atmospheric Pressure	Range 562 - 780 mm Hg

6.1.4. SPPL OPERATOR PANEL FEATURES

The operator panels shown in the following pages, supply a guide for the different S.P.P.L. models recognition.

ROSY 24.1 - 25

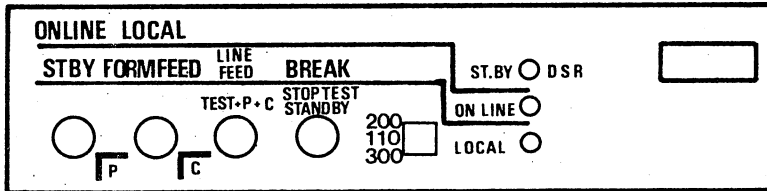

ROSY 24.1: TTY procedure type 30 CPS 300 BPS one-direction asynchronous terminal

ROSY 26.1

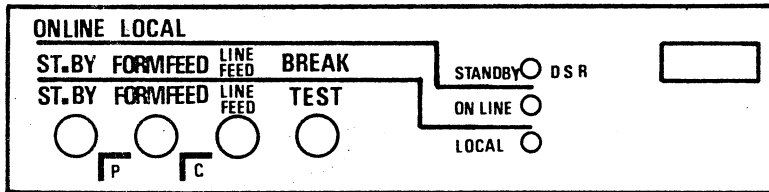

ROSY 26.1: TTY procedure type 160 CPS 1200 BPS one-direction asynchronous terminal

ROSY 72-74

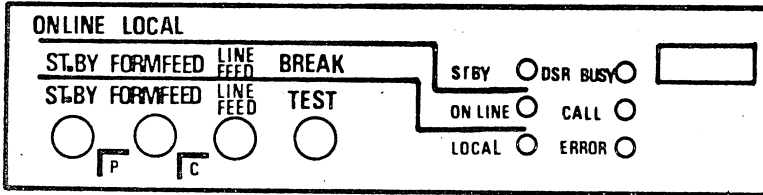

ROSY 72: TTY procedure type 120 CPS 1200 BPS one-direction asynchronous terminal

ROSY 74: TTY procedure type 120 CPS, 200/300/1200 BPS one-direction asynchronous terminal

SARA 2X

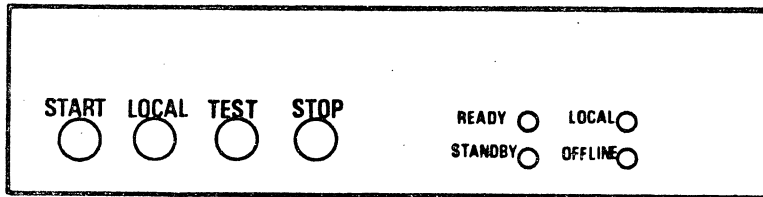

SARA 2X: 30 CPS asynchronous terminal with keyboard, or 30 or 120 CPS console printer

POLY 21-21.1

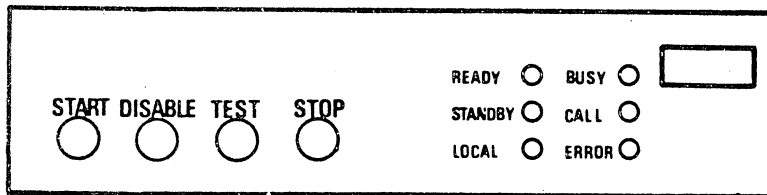

POLY 21: VIP procedure type 132 column, 120 CPS, 4800 BPS synchronous terminal

POLY 21.1.: VIP procedure type 132 column, 120 CPS, 4800 BPS synchronous terminal

ROSY 21

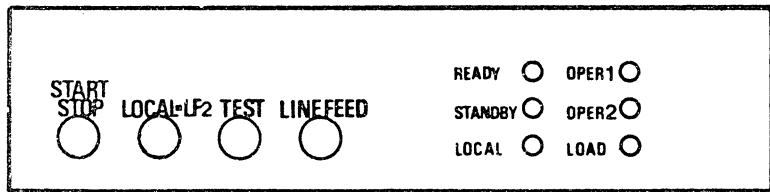

ROSY 21: 132 column, 120 CPS asynchronous terminal connected to 9600 BPS TTS 7800 DATA CAPTURE LINK (DCL)

ROSY 28

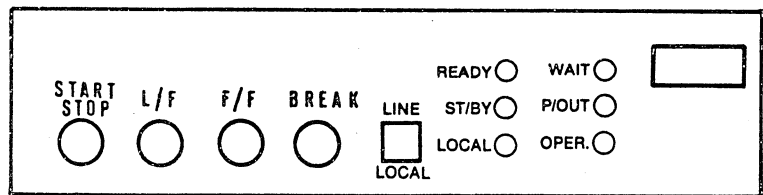

ROSY 28: TTY procedure type 180 CPS 2400 BPS two-direction asynchronous terminal

6.2 PHYSICAL INSTALLATION

6.2.1 Required Material

- . Personal F.E. Tools kit

6.2.2 Uncrating

The SPPL is shipped in a crate external to which the following information is given.

- . crate content
- . guide to unpack

Ensure that the unit is removed according to the unpacking guide and therefore inspect it for possible damages. Should damages caused by transport be detected, it will be necessary to:

- . have the carrier witness the entity of the damage
- . submit an immediate detailed report to the district manager
- Check that the contents tally with the form description stuck on the external side of the crate.
- Remove all crate contents and neatly set them aside
- The keyboard (Option) is shipped separately from the S.P.P.L. crate.

6.2.3 Completeness Check-out

The S.P.P.L. unit must be shipped complete of:

- 1 Product description manual
- 1 Inked ribbon cartridge
- 1 AC cable
- 1 Connection cable
- 1 Paper guide (only in presence of the Vpp option)

6.3 UNIT INSTALLATION

6.3.1. Required Material

Personal Tools Kit

6.3.2. Procedure Installation

- 1 - Remove the upper covers (fig. 6.2)
- 2 - Remove the paper feeding knob screw and extract the knob
- 3 - Remove the upper cover screws (4) (fig. 6.2)
- 4 - Remove the cover paying much attention in case either the V.F.U or the S.F.U. option is installed.

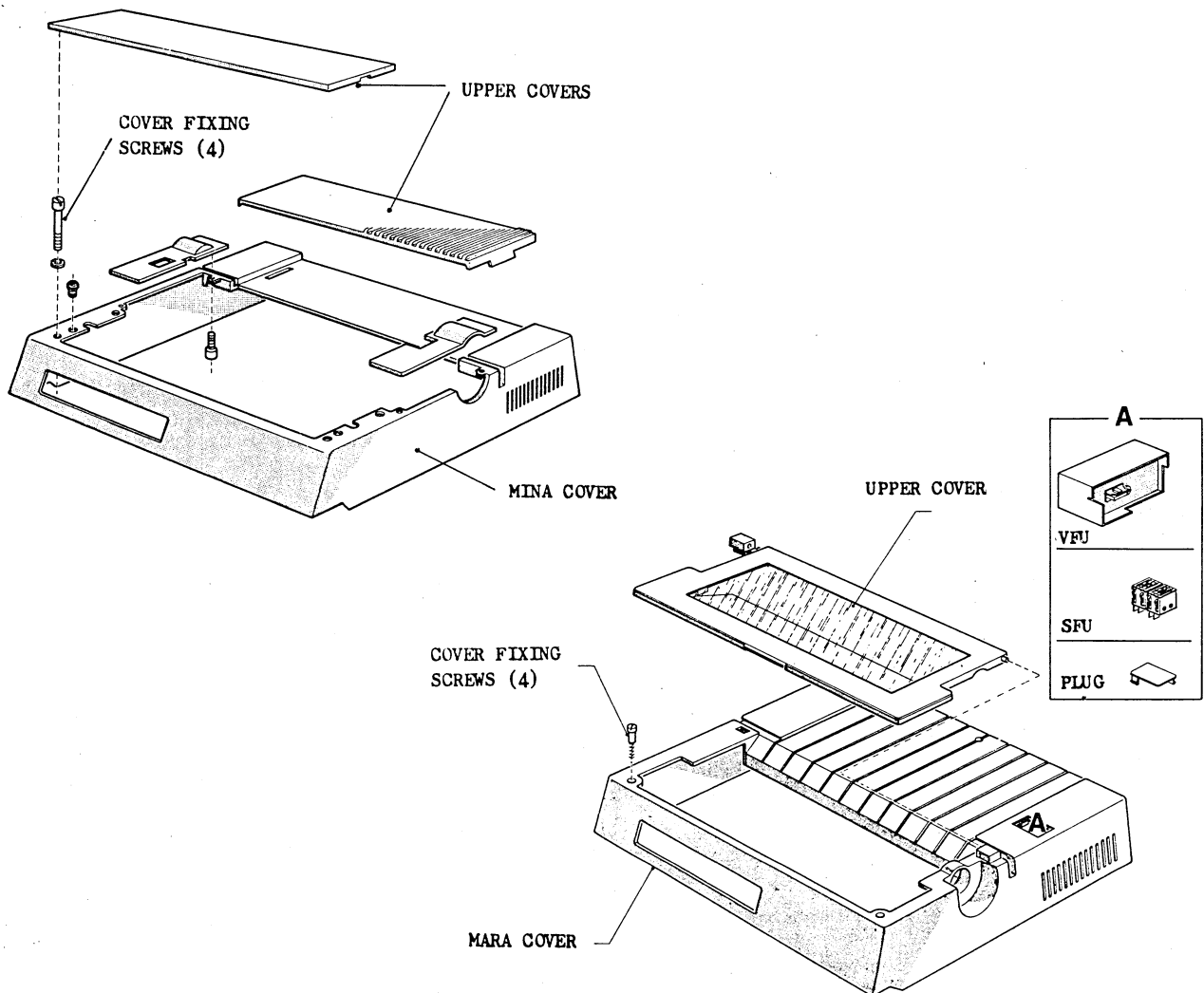

Fig. 6-2

- 5 - Check that the correct connection of cables and jumpers on the transformer terminal board coincides with the network voltage available (See fig. 6.3)

FOR OPERATION AT 220-240V 50Hz
208V 60HZ

FOR OPERATION AT 120-220-240V 50HZ

FROM		TO
J-29 01		T-01 J-01 05 A
T-01 J-01 06 B		T-01 J-01 01 A
T-01 J-01 02 B		T+01 J-01 04 A

FROM	TO
T-01 P-01 Yellow	C-01 -01
T-01 P-03 blue	CR01 -02
T-01 P-04 White	CR02 -02
T-01 P-05 White	CR02 -04

FOR OPERATION AT 120V 60HZ
120 V 50HZ

FOR OPERATION AT 208V 60HZ
120V 60HZ

FROM		TO
J-29 01		T-01 J-01 02 A
T-01 J-01 02B		T-01 J-01 05 A
T-01 J-01 01A		T-01 J-01 04 A

FROM	TO
T-01 P-02 Red	C-01 -01
T-01 P-03 Red	CR01 -02
T-01 P-04 Red	CR02 -02
T-01 P-05 Red	CR02 -04

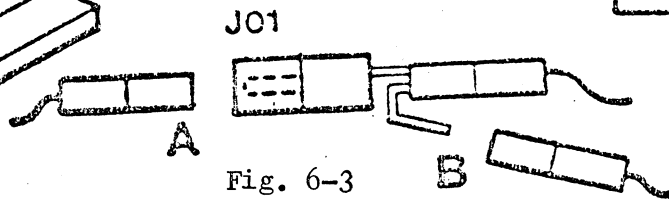
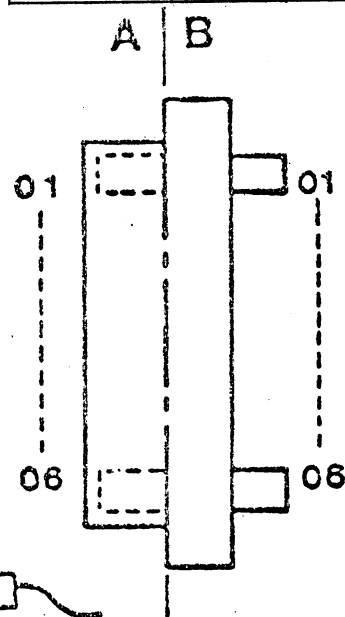
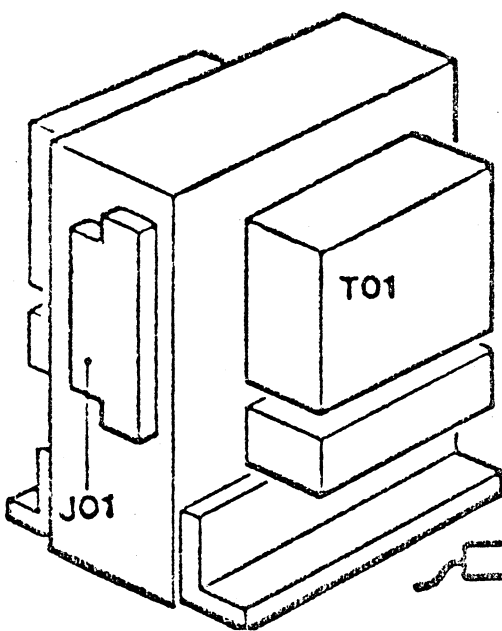

Fig. 6-3

71011350

- 6 - Should the type of power supply be changed, execute the connections as shown in the table above.
- 7 - Remove the cable from TB01 to C04 02 if the ground distribution points is not the SPPL (See dotted fine shown in fig. 6.4)

FOR OPERATION AT 220-240V 50Hz

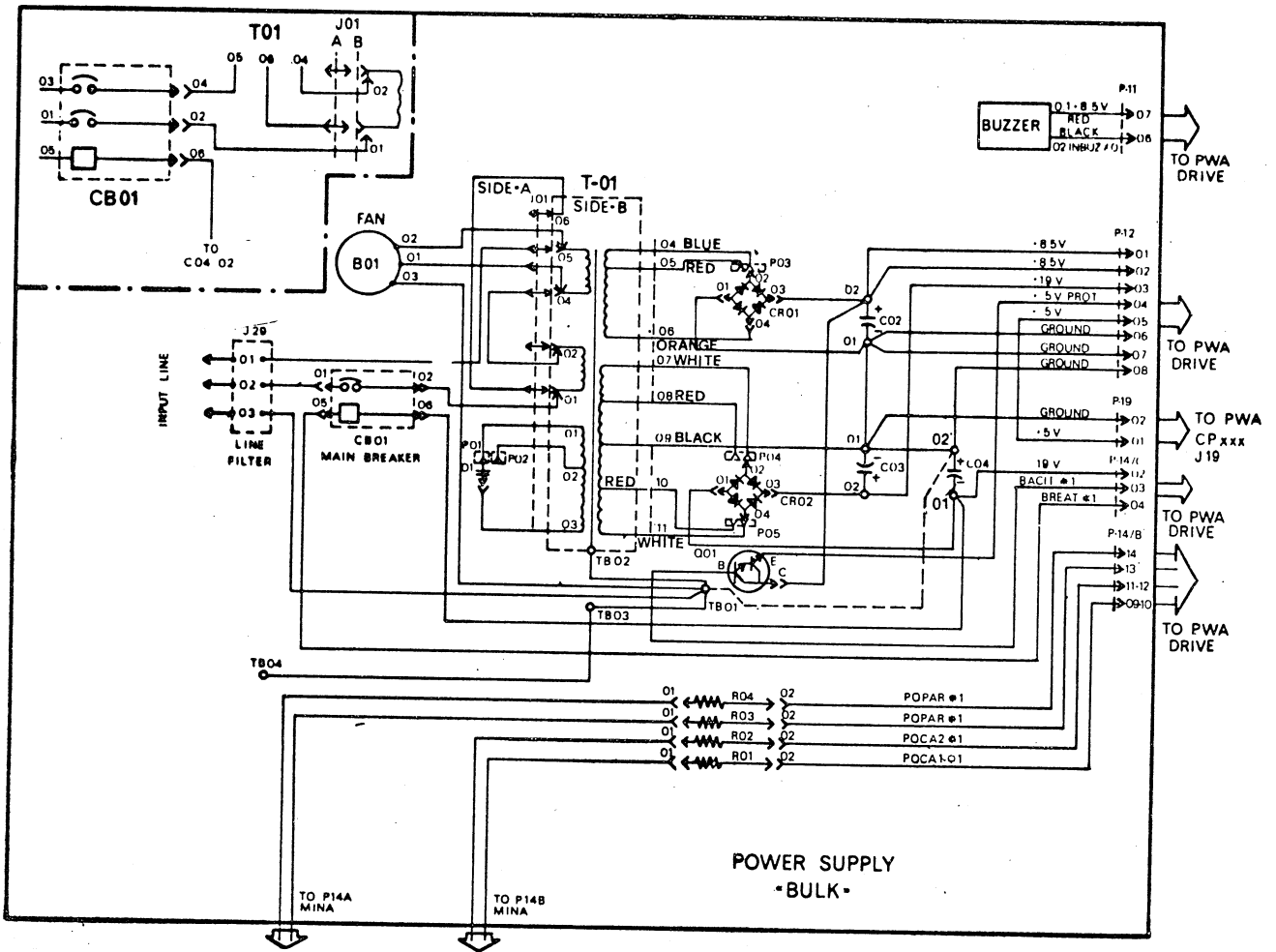

Fig. 6-4

- 8 - Remove the fastening strap which prevents the head from sliding (See fig. 6.5)
- 9 - Rotate the fixing post which locks the mechanics to the base to prevent damages caused by transport so as to make the mechanics rest on the vibrostops (See fig. 6.5)
- 10 - Extract the inked ribbon cartridge from its wrapping and remove the locking pin located on the right-hand of the knob. Fit the inked ribbon unit on the carriage and set the ribbon in front of the head (See fig. 6.5)

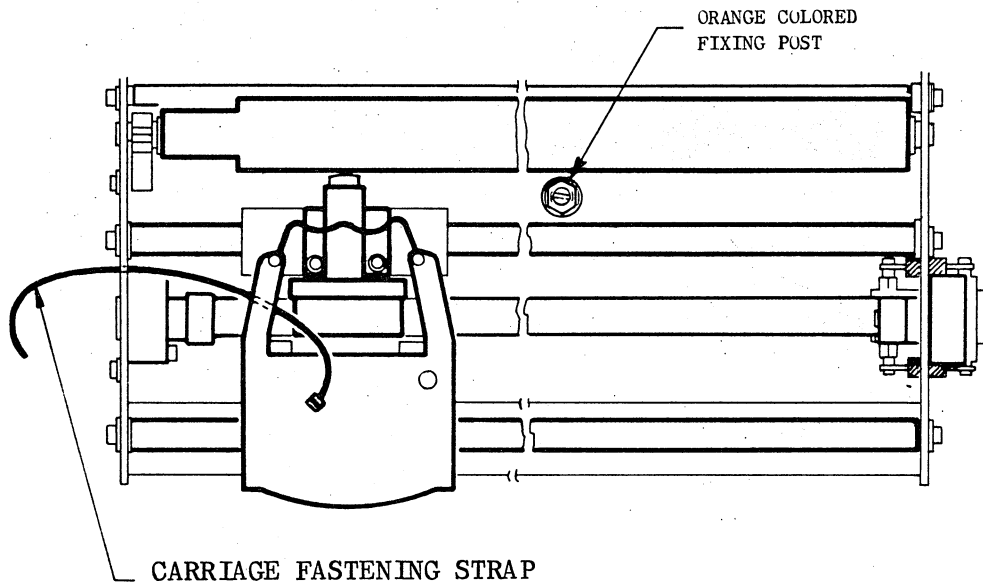

Fig. 6-5

- 11 - Cut if necessary, the jumper between pin 1 and pin 7 on the interface connector P26 so that this jumper is present only on one side when connecting the SPPL to the host (see fig. 6.6)
- 12 - Valid exclusively on Poly 21 - 21.1
Cut the jumpers between pins 10-15 and 24-17 on the internal interface connector P26 if the clocks are not to be provided by Poly (See fig. 6.6)

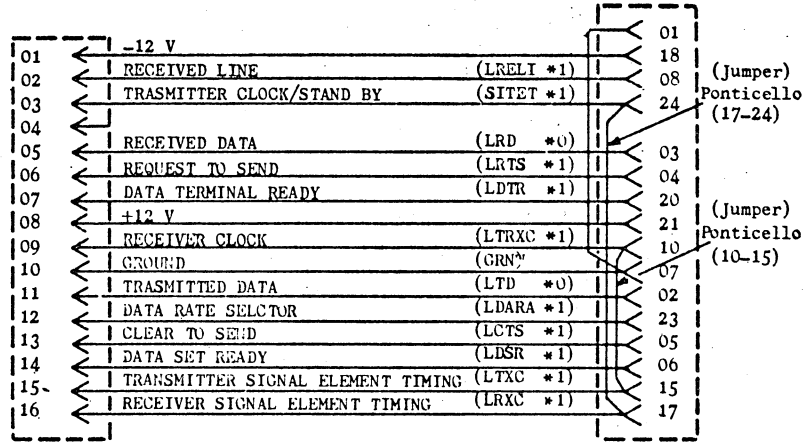

Fig. 6.6 - Modem Interface Cable (Internal) P/N 78118169-002

- 13 - Connect the interface cable (external) to the connector located on the rear left side of the unit.
- 14 - Connect the AC cable on the plug located on the unit rear right side.

CAUTION

On the SPPL units, the protection on the network input voltage is implemented by interrupting only the phase.

For this purpose, a polarized plug which must coincide with a sametype outlet, available at the customer site, is used on the power cable.

It is mandatory to comply with the polarities on the network power outlet as shown in fig. 6.7

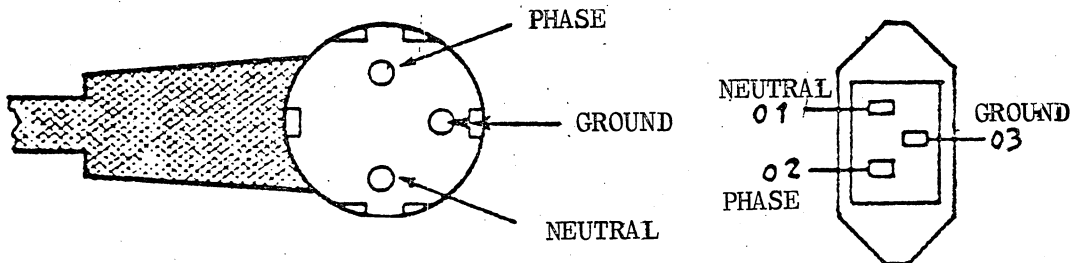

Fig. 6-7 Network Plug

The unit is not designed to be installed on IT type networks (isolated neutral)

- 15 - Install the keyboard (See para. 6.3.3)
- 16 - Install the V.P.P. paper guide (See para. 6.3.4.)
- 17 - Customize the PWA's (See para. 6.3.5.)
- 18 - Mount again all covers

6.3.3 Keyboard Installation

- Check that the unit is in the POWER OFF status
- Remove all covers (fig. 6.2)
- Fit the P25 connector of the keyboard cable into the keyboard (fig. 6.8)
- Insert the P02 connector of the keyboard cable through the right-hand side of the base and set it as shown in fig. 6.8

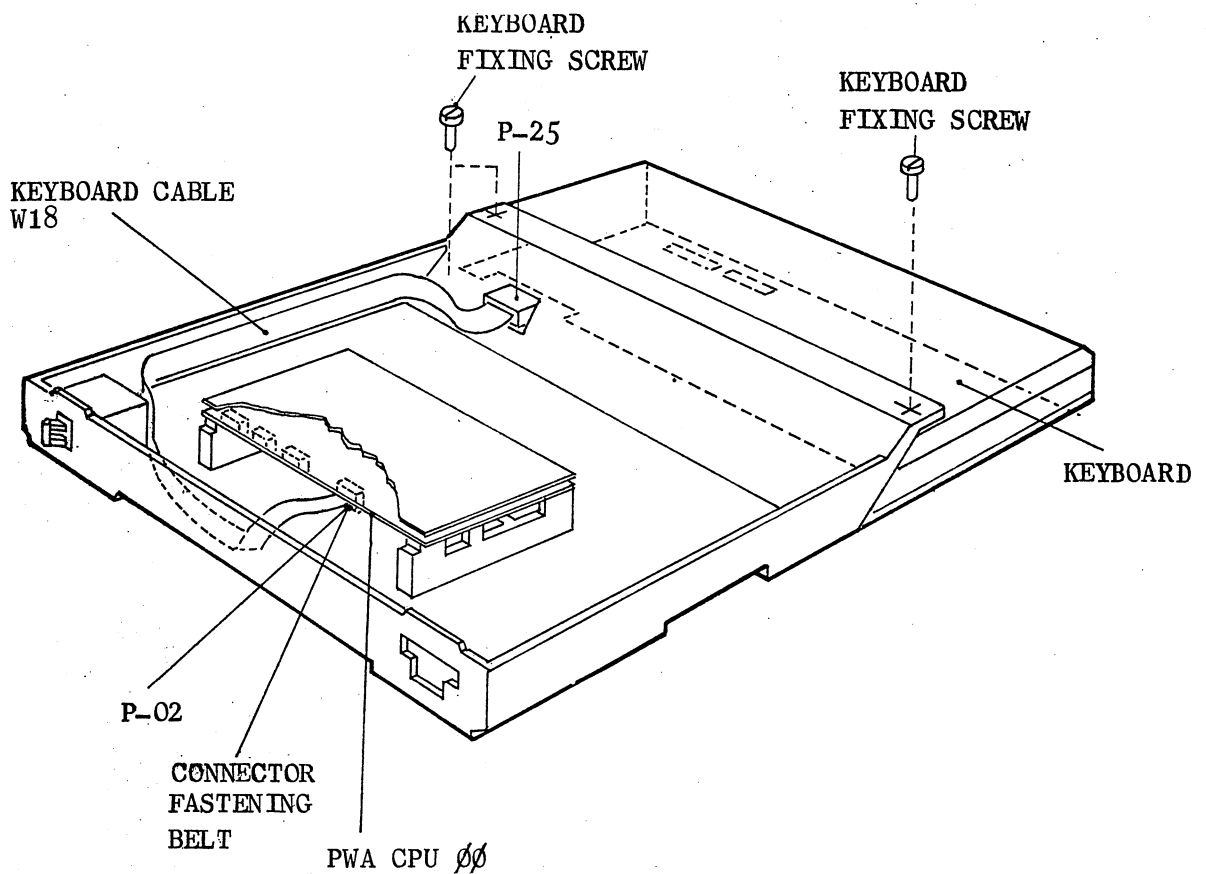
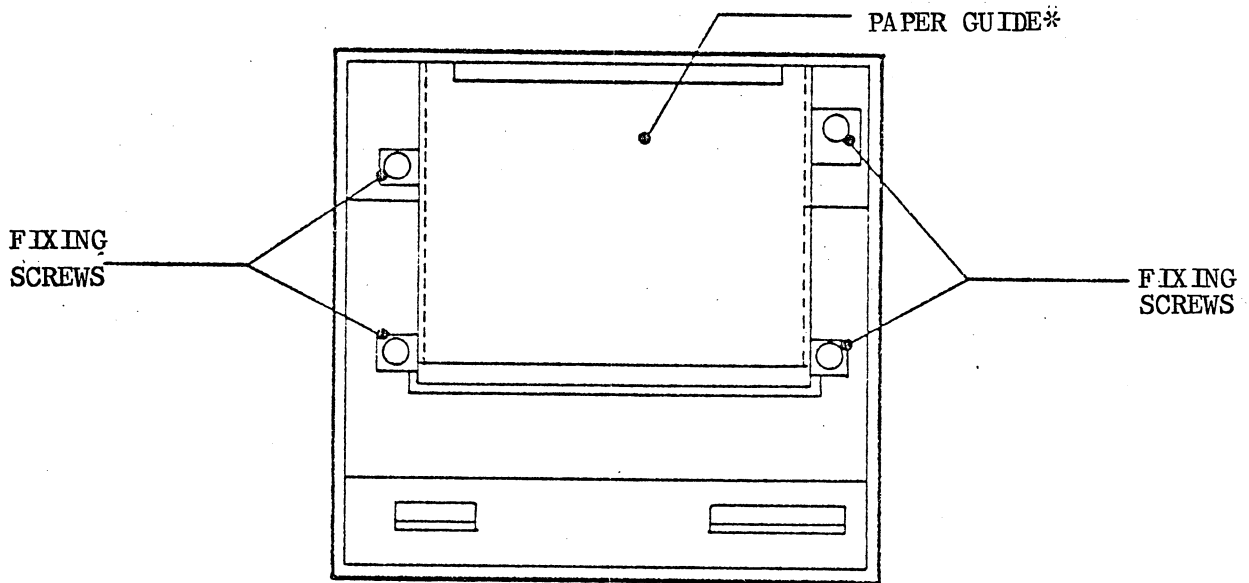

Fig. 6.8

- Set the keyboard assembly on the base and lock it through the fixing screws (2). (Fig. 6.8)
- Fit the P02 connector of the keyboard cable into the J02 connector of the CPU board and lock it by means of the appropriate band.
- Mount again all covers

6.3.4. "Vertical Paper Path" Paper Guide Installation

- For all units featuring the "Vertical Paper Path" option without the pedestal, and therefore placed on a table, it is necessary to mount the paper guide under the involved unit (Fig. 6.9)



*On the MARA mechanics, the paper guide is always factory installed

Fig. 6-9

6.3.5. SPPL CUSTOMIZATION

- Correctly set the switches on the CPU00, CPU28, CPU28B and DRIVE PWA's according to the delivery sheet.
Should the involved unit feature options requiring the customization of the involved PWA's, refer to the chapter 6.3.5.2

- 6.3.5.1 - Standard PWA'S
- Remove all covers.

- PWA DRIVE : USED ON ALL SPPL MODELS

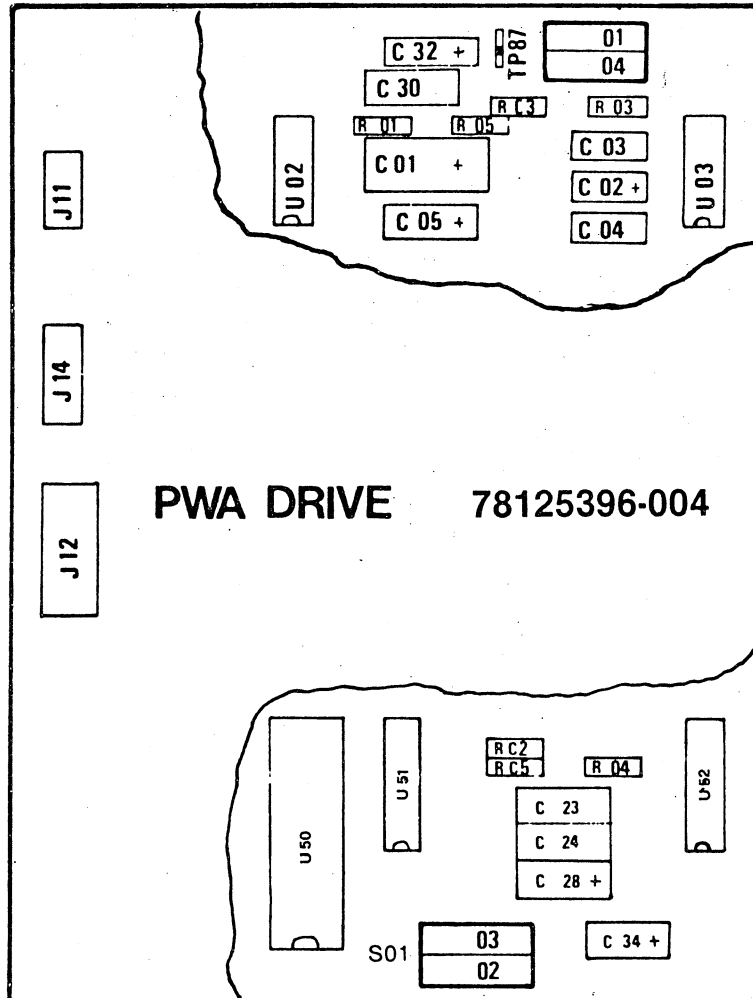

SWITCH	ROSY 26 1/28	USED ON ALL SPPL MODELS EXCEPT ROSY 26.1/28
S01		ALL MODELS EXCEPT ROSY 26.1/28
01	MUST BE OFF	MUST BE ON
04	MUST BE OFF	MUST BE ON
02	MUST BE OFF	MUST BE ON
03	MUST BE ON	MUST BE ON

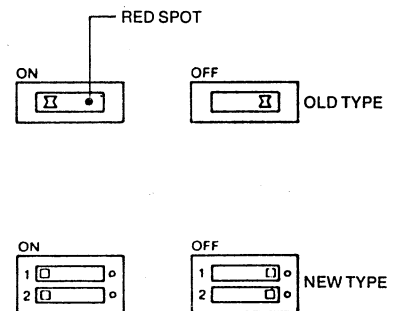

CORRECT SETTING OF THE SWITCHES ON THE INVOLVED PWA'S

- PWA CPU : used on all SPPL models except ROSY 28

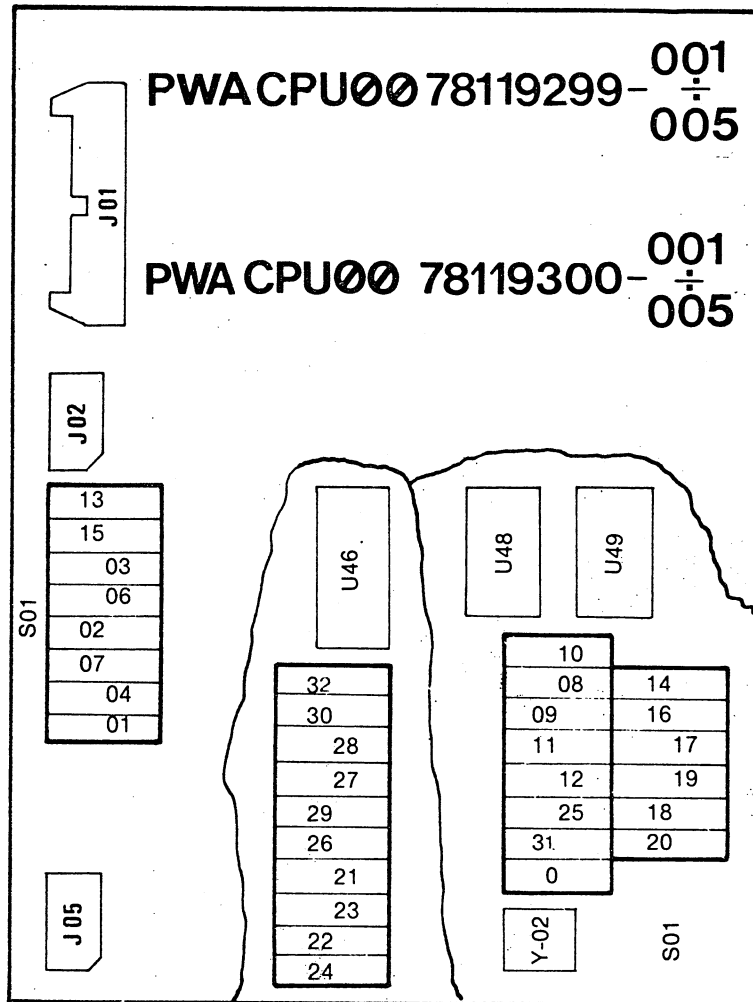

PWA CPU 00 78119299 - 001
005

PWA CPU 00 78119300 - 001
005

Switch S01-0 is equal to switch S01-05 mentioned in the notes

Refer to tables 1-8 on the following pages to correctly set the switches

CAUTION

If the involved unit is not correctly customized, upon the unit switching on the breaker can trip to power off.

SARA 2 X

ROSY 24.1

S-01 01	ON OFF	MUST BE OFF	300 BPS ONLY SELECTION 110-200-300 BPS SELECTION (1)
S-01 02	ON OFF	MUST BE OFF	MUST BE OFF
S-01 03	ON OFF	MUST BE OFF	MUST BE OFF
S-01 04	ON OFF	MUST BE OFF	110-200-300 BPS SELECTION 300 - BPS ONLY SELECTION (2)
S-01 05	ON OFF	MUST BE OFF	MUST BE OFF
S-01 06	ON OFF	MUST BE OFF	MUST BE ON
S-01 07	ON OFF	MUST BE ON	MUST BE OFF
S-01 08	ON OFF	INDIFFERENT	TAPE LOOP VFU OR NOT VFU OPT ROTARY SWITCHES SFU (21)
S-01 09	ON OFF	INDIFFERENT	SEE TABLE 3
S-01 10	ON OFF	IF KEY BOARD NPL (5) IF KEY BOARD NML	SHORT BREAK (100-150 ms) NORMAL BREAK (>200 ms) (22)
S-01 11	ON OFF	PRINT DIAMON. IF PARITY ERR. (6) NO CHECK PARITY	PRINT DIAMOND IF PARITY ERR. NO CHECK PARITY (6)
S-01 12	ON OFF	ODD PARITY (7) EVEN PARITY	SEE TABLE 3
S-01 13	ON OFF	MUST BE ON	MUST BE ON
S-01 14	ON OFF	INDIFFERENT	VT. ENABLED (ABILIT. TAB. VER.) VT. DISABLED (DISAB. TAB. VER.)
S-01 15	ON OFF	INDIFFERENT	LOCAL PRINT (9)
S-01 16	ON OFF	INDIFFERENT	READY STATUS AT POWER ON STAND BY STAT. AT POW. ON (24)
S-01 17	ON OFF	INDIFFERENT	PRINT UPPER CASE ONLY (13) PRINT UPPER & LOWER CASE
S-01 18	ON OFF	INDIFFERENT	ODD PARITY (7) EVEN PARITY
S-01 19	ON OFF	IF DIAG OPT NOT PRESENT (11) IF DIAG OPT PRESENT	132 COLUMNS 80 COLUMNS
S-01 20	ON OFF	INDIFFERENT	1 STOP BIT (12) 2 STOP BITS
S-01 21	ON OFF	INDIFFERENT	INDIFFERENT
S-01 22	ON OFF	INDIFFERENT	INDIFFERENT
S-01 23	ON OFF	INDIFFERENT	INDIFFERENT
S-01 24	ON OFF	INDIFFERENT	INDIFFERENT
S-01 25	ON OFF	MUST BE ON	WITHOUT AFF OPTION WITH AFF OPTION
S-01 26	ON OFF	MUST BE OFF	MUST BE OFF
S-01 27	ON OFF	MUST BE ON	MUST BE ON
S-01 28	ON OFF	MUST BE ON	MUST BE ON
S-01 29	ON OFF	MUST BE OFF	MUST BE OFF
S-01 30	ON OFF	INDIFFERENT	THIS SWIT MUST be set OFF ONLY FOR CONNECTION TO VIP 7200
S-01 31	ON OFF	INDIFFERENT	INDIFFERENT
S-01 32	ON OFF	MUST BE ON	MUST BE ON

ROSY 26.1

ROSY 25

S-01 01	ON OFF	MUST BE OFF	MUST BE OFF
S-01 02	ON OFF	MUST BE ON	MUST BE OFF
S-01 03	ON OFF	MUST BE OFF	MUST BE OFF
S-01 04	ON OFF	MUST BE OFF	MUST BE OFF
S-01 05	ON OFF	MUST BE OFF	MUST BE OFF
S-01 06	ON OFF	MUST BE ON	MUST BE ON
S-01 07	ON OFF	MUST BE OFF	MUST BE OFF
S-01 08	ON OFF	INDIFFERENT	TAPE LOOP VFU OR NOT VFU OPT ROTARY SWITCHES VFU (22)
S-01 09	ON OFF	READY STATUS AT POWER ON STAND BY STATUS AT POW. ON	SEE TABLE 3
S-01 10	ON OFF	132 COLUMNS 80 COLUMNS (24)	SHORT BREAK (100 + 150 ms) NORMAL BREAK (>200 ms) (23)
S-01 11	ON OFF	PRINT DIAMON. IF PARITY ERR. NO CHECK PARITY (6)	PRINT DIAMOND IF PARITY ERR. NO CHECK PARITY (6)
S-01 12	ON OFF	SEE TABLE 7	SEE TABLE 3
S-01 13	ON OFF	MUST BE ON	MUST BE ON
S-01 14	ON OFF	NORMAL CONNECTION VIP 7200 CONNECTION	VT. ENABLED (ABILIT. TAB VER.) VT. DISABLED (DISAB TAB VER.)
S-01 15	ON OFF	FULL DUPLEX MODE HALF DUPLEX MODE (16)	LOCAL PRINT
S-01 16	ON OFF	ENABLE VT OPTION DISABLE VT OPTION	READY STATUS AT POWER ON STAND BY STAT AT POW ON (24)
S-01 17	ON OFF	SEE TABLE 7	PRINT UPPER CASE ONLY (13) PRINT UPPER & LOWER CASE
S-01 18	ON OFF	LOCAL PRINT (9)	ODD PARITY (7) EVEN PARITY
S-01 19	ON OFF	BUFFER OVER FLOW SIGNAL	132 COLUMNS 80 COLUMNS
S-01 20	ON OFF	PRINT UPPER & LOWER CASE PRINT UPPER CASE ONLY (13)	1 STOP BIT (12) 2 STOP BITS
S-01 21	ON OFF	INDIFFERENT	INDIFFERENT
S-01 22	ON OFF	INDIFFERENT	INDIFFERENT
S-01 23	ON OFF	INDIFFERENT	INDIFFERENT
S-01 24	ON OFF	INDIFFERENT	INDIFFERENT
S-01 25	ON OFF	WITHOUT AFF OPTION WITH AFF OPTION	WITHOUT AFF OPTION WITH AFF OPTION
S-01 26	ON OFF	MUST BE OFF	MUST BE OFF
S-01 27	ON OFF	MUST BE ON	MUST BE ON
S-01 28	ON OFF	MUST BE ON	MUST BE ON
S-01 29	ON OFF	MUST BE OFF	MUST BE OFF
S-01 30	ON OFF	VFU BY LOOP OR NOT VFU OPT. SFU OPTION	THIS SWIT. MUST be set OFF ONLY FOR CONNECTION TO VIP 7200
S-01 31	ON OFF	MUST BE OFF	INDIFFERENT
S-01 32	ON OFF	MUST BE ON	MUST BE ON

ROSY 72/74

ROSY 21

S-01 01	ON OFF	SEE TABLE 4	MUST BE ON
S-01 02	ON OFF	SEE TABLE 4	MUST BE ON
S-01 03	ON OFF	SEE TABLE 4	MUST BE OFF
S-01 04	ON OFF	MUST BE OFF	MUST BE OFF
S-01 05	ON OFF	MUST BE OFF	MUST BE ON
S-01 06	ON OFF	MUST BE ON	MUST BE ON
S-01 07	ON OFF	MUST BE OFF	MUST BE OFF
S-01 08	ON OFF	IF KEYBOARD VIP IF KEYBOARD NML	PRINT UPPER AND LOW. CASE PRINT UPPER CASE ONLY
S-01 09	ON OFF	SEE TABLE 5	INDIFFERENT
S-01 10	ON OFF	132 COLUMNS 80 COLUMNS	INDIFFERENT
S-01 11	ON OFF	PARITY ERROR CHECK NO PARITY CHECK (6)	INDIFFERENT
S-01 12	ON OFF	SEE TABLE 5	INDIFFERENT
S-01 13	ON OFF	MUST BE ON	MUST BE ON
S-01 14	ON OFF	AT POWER ON READY STATUS AT POWER ON ST/BY STATUS	38/120 CPS 38 CPS ONLY
S-01 15	ON OFF	NO LOCAL PRINT (9) LOCAL PRINT	2 ND DCL NOT PRESENT 2ND DCL PRESENT
S-01 16	ON OFF	INDIFFERENT	MUST BE ON
S-01 17	ON OFF	UPPER CASE ONLY UPPER & LOWER CASE	WITHOUT AFF OPTION WITH AFF OPTION
S-01 18	ON OFF	ODD PARITY (7) EVEN PARITY	MUST BE ON
S-01 19	ON OFF	DIAGN. OPT. NOT PRESENT (11) DIAGN. OPT. PRESENT	DIAGN. OPT. NOT PRESENT (11) DIAGN. OPT. PRESENT
S-01 20	ON OFF	INDIFFERENT	INDIFFERENT
S-01 21	ON OFF	MUST BE ON	MUST BE OFF
S-01 22	ON OFF	MUST BE OFF	MUST BE ON
S-01 23	ON OFF	MUST BE OFF	MUST BE OFF
S-01 24	ON OFF	MUST BE ON	MUST BE OFF
S-01 25	ON OFF	MUST BE OFF "WITH AFF OPTION"	AFF INTERRUPT DISABLED AFF INTERRUPT ENABLE
S-01 26	ON OFF	MUST BE OFF	MUST BE OFF
S-01 27	ON OFF	MUST BE ON	MUST BE ON
S-01 28	ON OFF	MUST BE ON	MUST BE ON
S-01 29	ON OFF	MUST BE OFF	MUST BE OFF
S-01 30	ON OFF	FULL DUPLEX (16) HALE DUPLEX	NO VISIBILITY OPTION VISIBILITY OPTION
S-01 31	ON OFF	MUST BE OFF	INDIFFERENT
S-01 32	ON OFF	MUST BE ON	MUST BE ON

POLY 21.1

POLY 21

S-01 01	ON OFF	SEE TABLE 1	SEE TABLE 1	
S-01 02	ON OFF	SEE TABLE 1	SEE TABLE 1	
S-01 03	ON OFF	SEE TABLE 1	SEE TABLE 1	
S-01 04	ON OFF	MUST BE OFF	MUST BE OFF	
S-01 05	ON OFF	SEE TABLE 1	SEE TABLE 1	
S-01 06	ON OFF	MUST BE ON	MUST BE ON	
S-01 07	ON OFF	MUST BE OFF	MUST BE OFF	
S-01 08	ON OFF	TERM ADDRESS BIT 0	TERM ADDRESS BIT 0	
S-01 09	ON OFF	TERM ADDRESS BIT 1	TERM ADDRESS BIT 1	
S-01 10	ON OFF	TERM ADDRESS BIT 2	TERM ADDRESS BIT 2	
S-01 11	ON OFF	TERM ADDRESS BIT 3	TERM ADDRESS BIT 3	
S-01 12	ON OFF	TERM ADDRESS BIT 4	TERM ADDRESS BIT 4	
S-01 13	ON OFF	MUST BE ON	MUST BE ON	
S-01 14	ON OFF	QUIESCENT FRAME EOT (14) QUIESCENT FRAME SOH EOT	QUIESCENT FRAME EOT (14) QUIESCENT FRAME SOH EOT	
S-01 15	ON OFF	ACK+TEXT MESSAGE IGNOR ACK+TEXT MESSAGE HAND	ACK+TEXT MESSAGE IGNORED ACK+TEXT MESSAGE HANDLED	
S-01 16	ON OFF	L66 CONNECTION OTHER CONNECTION	INDIFFERENT	
S-01 17	ON OFF	POLLED PROCEDURE NO POLLED PROCEDURE (15)	POLLED PROCEDURE NO POLLED PROCEDURE (15)	
S-01 18	ON OFF	HALF DUPLEX FULL DUPLEX (16)	HALF DUPLEX FULL DUPLEX (16)	
S-01 19	ON OFF	IF DIAG OPT NOT PRESENT IF DIAG OPT PRESENT (11)	IF DIAG OPT NOT PRESENT IF DIAG OPT PRESENT (11)	
S-01 20	ON OFF	LRC CHECK ENABLED LRC CHECK DISABLED (17)	LRC CHECK ENABLED LRC CHECK DISABLED (17)	
S-01 21	ON OFF	PUT ON SELECT STAND BY PUT OFF SELECT STAND BY (18)	PUT ON SELECT STAND BY PUT OFF SELECT STAND BY (18)	
S-01 22	ON OFF	PUT ON DATA RATE SEL PUT OFF DATA RATE SEL (19)	PUT ON DATA RATE SEL PUT OFF DATA RATE SEL (19)	
S-01 23	ON OFF	SEE TABLE 2 (20)	SEE TABLE 2 (20)	
S-01 24	ON OFF	SEE TABLE 2 (20)	SEE TABLE 2 (20)	
S-01 25	ON OFF	AFF INTERRUPT DISABLED AFF INTERRUPT ENABLED	AFF INTERRUPT DISABLED AFF INTERRUPT ENABLED	
S-01 26	ON OFF	MUST BE ON	MUST BE ON	
S-01 27	ON OFF	MUST BE OFF	MUST BE OFF	
S-01 28	ON OFF	MUST BE OFF	MUST BE OFF	
S-01 29	ON OFF	MUST BE ON	MUST BE ON	
S-01 30	ON OFF	SEE TABLE 8	SEE TABLE 8	
S-01 31	ON OFF	INDIFFERENT	INDIFFERENT	
S-01 32	ON OFF	MUST BE OFF	MUST BE OFF	

TABLE 1

POLY 21/21.1

S-01 05	S-01 01	S-01 02	S-01 03	SPEED
OFF	OFF	ON	OFF	1200 B/S
ON	ON	OFF	OFF	2400 B/S
OFF	ON	ON	OFF	4800 B/S

TABLE 2

POLY 21/21.1

S-01 23	S-01 24	
ON	OFF	SELECT "SELECT STAND-BY"
OFF	ON	SELECT "TRANS ELEMENT TIMING"
OFF	OFF	NO SELECTION
ON	ON	NO ALLOWED

TABLE 3

ROSY 24.1-25

S-01 09	S-01 12	KEYBOARD INSTALLED TYPE
ON	ON	QWERTY INTERNATIONAL
OFF	ON	AZERTY INTERNATIONAL
ON	OFF	QWERTZ INTERNATIONAL
OFF	OFF	MAIF MAAF (CII-HB CUSTOMER)
INDIFFERENT WITH "NATIONAL" KEYBOARDS OR WITHOUT KEYBOARD		

TABLE 4

ROSY 72-74

S-01 01	S-01 02	S-01 03	SPEED
ON	OFF	ON	200 B/S
ON	OFF	OFF	300 B/S
OFF	ON	OFF	1200B/S

TABLE 5

ROSY 72-74

S-01 09	S-01 12	MEAN
ON	ON	QWERTY INTERNATIONAL
OFF	ON	AZERTY INTERNATIONAL
ON	OFF	QWERTZ INTERNATIONAL
OFF	OFF	NOT OPERABLE
INDIFFERENT FOR "NATIONAL" KEY BOARDS		

TABLE 6

POLY 21/21.1

S-01 12	S-01 11	S-01 10	S-01 09	S-01 08	HEXADECI. ADDRESS	DECIMAL ADDRESS
ON	ON	ON	ON	ON	00H	0
ON	ON	ON	ON	OFF	01H	1
ON	ON	ON	OFF	ON	02H	2
ON	ON	ON	OFF	OFF	03H	3
ON	ON	OFF	ON	ON	04H	4
ON	ON	OFF	ON	OFF	05H	5
ON	ON	OFF	OFF	ON	06H	6
ON	ON	OFF	OFF	OFF	07H	7
ON	OFF	ON	ON	ON	08H	8
ON	OFF	ON	ON	OFF	09H	9
ON	OFF	ON	OFF	ON	0AH	10
ON	OFF	ON	OFF	OFF	0BH	11
ON	OFF	OFF	ON	ON	0CH	12
ON	OFF	OFF	ON	OFF	0DH	13
ON	OFF	OFF	OFF	ON	0EH	14
ON	OFF	OFF	OFF	OFF	0FH	15
OFF	ON	ON	ON	ON	10H	16
OFF	ON	ON	ON	OFF	11H	17
OFF	ON	ON	OFF	ON	12H	18
OFF	ON	ON	OFF	OFF	13H	19
OFF	ON	OFF	ON	ON	14H	20
OFF	ON	OFF	ON	OFF	15H	21
OFF	ON	OFF	OFF	ON	16H	22
OFF	ON	OFF	OFF	OFF	17H	23
OFF	OFF	ON	ON	ON	18H	24
OFF	OFF	ON	ON	OFF	19H	25
OFF	OFF	ON	OFF	ON	1AH	26
OFF	OFF	ON	OFF	OFF	1BH	27
OFF	OFF	OFF	ON	ON	1CH	28
OFF	OFF	OFF	ON	OFF	1DH	29
OFF	OFF	OFF	OFF	ON	1EH	30
OFF	OFF	OFF	OFF	OFF	1FH	31

TABLE 7

ROSY 26.1

S01 12	S01 17	MEAN
ON	INDIF.	QWERTY INTERNATIONAL
OFF	OFF	AZERTY INTERNATIONAL
OFF	ON	QWERTZ INTERNATIONAL
X	X	W/O KEYBOARD
OFF	X	WITH "NATIONAL" C/G AND KEYBOARD

X = INDIFFERENT

TABLE 8

POLY 21 - 21.1

S01 30	KEYBOARD	EPROM CHIP C/GENERATOR
ON	QWERTY	6525 - 96 AZERTY
OFF	AZERTY	6525 - 96 AZERTY
ON	QWERTY	6537 - 96 QWERTZ
OFF	QWERTZ	6537 - 96 QWERTZ
ON	QWERTY	6544 - FRA/BEL.
OFF	AZERTY	6544 - FRA/BEL.
OFF	QWERTZ	6542 - GER/AUS.
ON	FOR THE OTHER "NATIONAL" KEYBOARD.	

NOTES

- | | |
|--|--|
| <p>(1) With S-01 - 01 set to ON, the communication is allowed only with the 300 bps speed. With S-01 - 01 set to OFF, the transmission speed is defined by the switch setting on the operator panel.</p> <p>(2) S-01 - 04 must be set according to S-01 - 01.</p> <p>(3) S-01 - 08 must be set to ON only when the Automatic Front Feed (I.P.I GTWF 342/345) option is present.</p> <p>(4) For the ROSY 24 unit, S-01 - 09 is always set to ON.</p> <p>(5) S-01 - 10 must be set to ON only in presence of the NPL type keyboard which can be identified by the ATTENTION/CANCEL/EXECUTE keys, otherwise must be set to OFF.</p> <p>(6) S-01 - 11 must be set to ON if a character integrity check (odd or even) is required. If the check is used, a rhomb is printed in place of each wrong character.</p> <p>(7) If a parity check is selected (S-01 - 11 be set to ON), define if this is ODD or EVEN. If this switch is incorrectly set, rhombs are printed in place of characters.</p> <p>(8) For the ROSY 24 model, S-01 - 12 must be set to ON. For the ROSY 24.1 model, see table 3 on page 5.</p> <p>(9) This switch must be set to ON if the system comprises the ECOPLEX feature and to OFF if does not comprise the ECOPLEX. This is necessary to display the typed message. If the switch is incorrectly set, the symptoms are failure of the message print (ON in FULL DUPLEX without ECOPLEX) or doubling of the typed character (OFF in FULL DUPLEX with ECOPLEX).</p> <p>(10) When the AFF is present, with S-01 - 16 set to ON, either the paper mounted on the tractors or the form inserted in the AFF can be indifferently moved. If S-01 - 16 is set to OFF, the paper mounted on the tractors can be moved only if there is no form in the AFF. This in accordance to the customer requirements.</p> <p>(11) S-01 - 19 set to OFF enables the launch of the internal diagnostic routines when the pertinent option is installed (Eprom chip-see section VII Fault Diagnosis).</p> <p>(12) Set S-01 - 20 according to the format of the message used in the connection. As a general rule 1 STOP bit is used for 200/300 bauds and 2 for 110 bauds.</p> <p>(13) This model can print either the only upper case or the upper & lower case graphic set. Set the switch according to the features paid by the customer.</p> | <p>(14) In the VIP procedure the terminal is foreseen to supply an answer to the system when the connection is over. Set S-01 - 14 to ON if the answer requested by the system is only EOT and to OFF if the answer must be SOH plus EOT.</p> <p>(15) The POLLED procedure is used when different terminals are connected on the same network and therefore each one is required to be identified by an identification code. The code is defined by the S-01 - 08 to 12 switches setting according to the setting defined by the system. The NON POLLED procedure is used when only one terminal is connected.</p> <p>(16) HALF 2 wire connection
FULL 4 wire connection</p> <p>(17) S-01 - 20 must be set to ON if the longitudinal parity check of the messages is to be enabled. If an error is present, the ERROR indicator lights up and a NACK is transmitted to the system.</p> <p>(18) In Italy S-01 - 21 is always set to OFF.</p> <p>(19) The DATA RATE SELECT is an interface signal which establishes the speed to be selected to execute the connection with double speed SYNCHRONOUS MODEMS. Therefore set S-01 - 22 as required by the connection.</p> <p>(20) The synchronous MODEMS provide the clock for the dialogue. Therefore for the POLY remote connection, set S-01 - 23 and 24 to OFF. For a direct connection, the clock must be provided by the terminal; therefore S-01 - 23 is set to OFF and S-01 - 24 is set to ON.</p> <p>(21) S-01 - 08 must be set to ON when the VFU option is not present or it is present but is the punched band type. When the SFU with rotary switches is installed, set S-01 - 08 to OFF.</p> <p>(22) Set S-01 - 10 so as to set the BREAK length required by the connection. In Italy the standard length is 200 ms.</p> <p>(23) With S-01 - 16 set to ON, whenever a cause which sets the SPPL to ST.BY occurs, a BREAK is generated and the DATA TERMINAL READY signal remains high as not to have the modems disconnected. With S-01 - set to OFF, DATA TERMINAL READY goes to OFF for ST.BY and, if the modem is the American type, a line disconnection occurs.</p> |
|--|--|

- CPU 280/CPU28B PWA's: used only on ROSY 28



S-00+S-17

	ON	OFF	
S-00	ON	OFF	MUST BE OFF
S-01	ON	OFF	(KEY BOARD) SEE TABLE 1
	ON	OFF	
S-02	ON	OFF	UPPER CASE ONLY UPPER CASE & LOWER CASE
	ON	OFF	
S-03	ON	OFF	(LINE FUNCTIONS) SEE TABLE 2
	ON	OFF	
S-04	ON	OFF	EVEN PARITY GENERATION ODD PARITY GENERATION
	ON	OFF	
S-05	ON	OFF	LOCAL PRINT NO LOCAL PRINT
	ON	OFF	
S-06	ON	OFF	CHARACTERS ALINEAMENT AND ADJUSTEMENT
	ON	OFF	
S-07	ON	OFF	SEE TABLE 3
	ON	OFF	
S-08	ON	OFF	ENABLE VIP HARD COPY CONNECT. DISABLE VIP HARD COPY CONNECT.
	ON	OFF	
S-09	ON	OFF	N.V.M. OPTION NO N.V.M. OPTION
	ON	OFF	
S-10	ON	OFF	BUSY INDICATION ENG PROCEDURE
	ON	OFF	
S-11	ON	OFF	SPH OPTION QFAM OPTION
	ON	OFF	
S-12	ON	OFF	1200 BPS WITHOUT A.O.P. SPEED BY A.O.P.
	ON	OFF	
S-13	ON	OFF	INCOTERM CONNECTION ALL OTHERS CONNECTIONS
	ON	OFF	

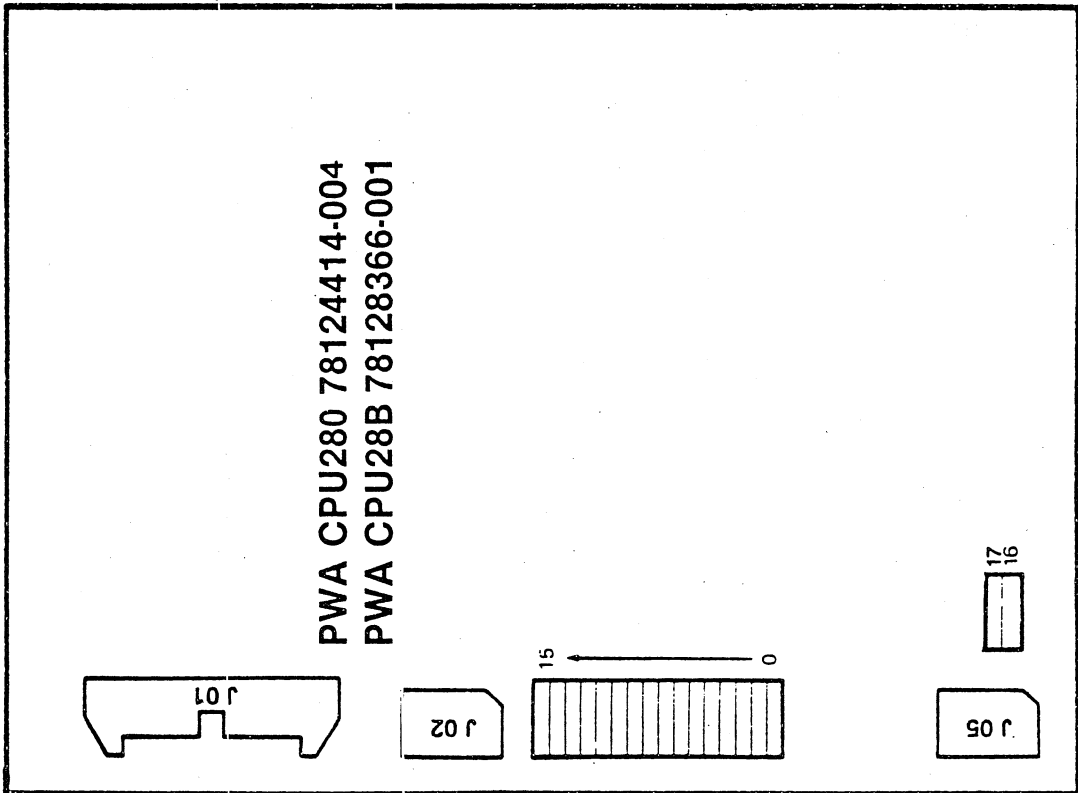

TABLE 1

S-01	S-02	MEAN
ON	ON	QWERTY INTERNATIONAL
ON	OFF	AZERTY "
OFF	ON	QWERTZ "
OFF	OFF	NO KEY BOARD

TABLE 2

S-04	S-05	S-06	MEAN
ON	ON	ON	FDX TWA
OFF	ON	ON	FDX TWS or CL TWS
ON	OFF	ON	NOT USED
OFF	OFF	ON	BUSY LEVEL ON DEDICATED PIN
ON	ON	OFF	HDX & RC
OFF	ON	OFF	HDX CLC (TX AT POWER ON)
ON	OFF	OFF	NOT USED
OFF	OFF	OFF	HDX CLC (RX AT POWER ON)

TABLE 3

S-09	S-10	S-11	VALUE OF ADJUSTMENT
ON	ON	ON	0
OFF	ON	ON	1
ON	OFF	ON	2
OFF	OFF	ON	3
ON	ON	OFF	4
OFF	ON	OFF	5
ON	OFF	OFF	6
OFF	OFF	OFF	7

6.3.5.2 - Optional PWA's

. AFF/AFFE PWA

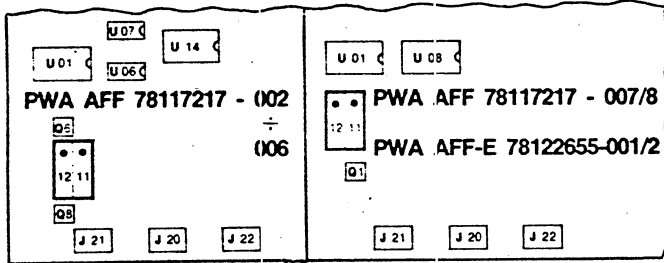

POLY 21

SWITCH SETTING

S 01-11	S 01-12	FIRST PRINTABLE COLUMN ON THE SINGLE SHEET
ON	ON	COLUMN 85
OFF	ON	COLUMN 93
ON	OFF	COLUMN 53
OFF	OFF	COLUMN 61

ROSY 82

SWITCH SETTING

S01-11	MUST BE OFF
S01-12	MUST BE OFF

ROSY 24.1 - 26.1 - LINA 4X

PWA AFF SWITCH SETTING

S 01-11	ON	SINGLE SHEET+FANFOLD MOVEMENT
	OFF	SINGLE SHEET ONLY MOVEMENT
S 01-12	ON	S.S. FIRST PRINTABLE COLUMN AT 56
	OFF	S.S. FIRST PRINTABLE COLUMN AT 53

ROSY 21

PWA AFF SWITCH SETTING

S 01-11		FIRST PRINTABLE COLUMN ON THE SINGLE SHEET
ON	ON	COLUMN 85
ON	OFF	COLUMN 93
OFF	ON	COLUMN 53
OFF	OFF	COLUMN 61

ROSY 72-74

S01-11	INDIFFERENT
S01-12	INDIFFERENT

. MIPI PWA

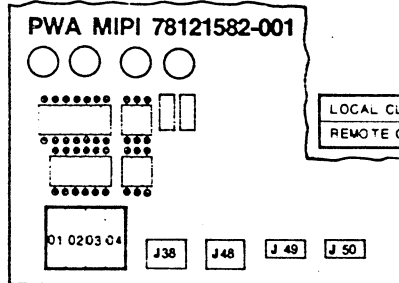

PWA MIPI SWITCH SETTING

	S-01	S-02	S-03	S-04
LOCAL CLOCK CONN	ON	CN	OFF	OFF
REMOTE CLOCK CONN.	OFF	OFF	ON	CN

. DCL PWA

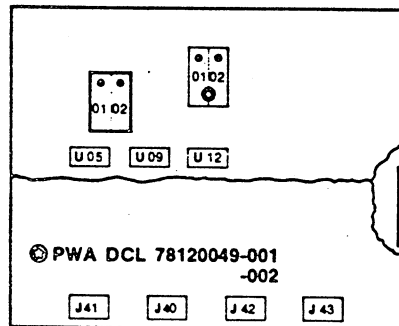

PWA DCL SETTING SWITCH

MODELS	S01	S02
ROSY 21	CN	OFF
ROSY 82	OFF	ON

LOOCU/LOSFU PWA

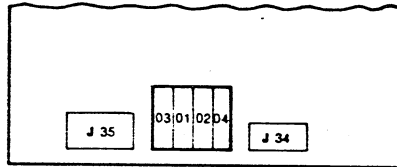

PWA LOSFU 78120683
PWA LOOCU 78121029

SETTING SWITCHES

THIS INSTRUCTIONS ARE USEFUL FOR ALL LCSP MOS MODELS (SARA - ROSY 24 - ROSY 26)	S01 03	S01 01	S01 02	S01 04
	OFF	ON	OFF	ON
INTERFACE CURRENT PROVIDED BY EXTERNAL SOURCE	ON	OFF	ON	ON
INTERFACE CURRENT PROVIDED BY LOOCU-LOSFU BOARD	ON	OFF	ON	ON

CRL 96 PWA

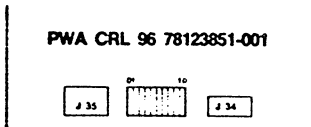

PERSONALIZZAZIONE PWA CRL 96

S - 01	ON	MUST BE OFF
	OFF	
S - 02	ON	ACTIVE
	OFF	PASSIVE
S - 03	ON	PASSIVE
	OFF	ACTIVE
S - 04	ON	ACTIVE
	OFF	PASSIVE
S - 05	ON	MUST BE OFF
	OFF	
S - 06	ON	MUST BE OFF
	OFF	
S - 07	ON	ACTIVE
	OFF	PASSIVE
S - 08	ON	PASSIVE
	OFF	ACTIVE
S - 09	ON	ACTIVE
	OFF	PASSIVE
S - 10	ON	OPT INCOTERM (GTWF 341J)
	OFF	OPT 4 WIRE (GTWF 341E)

PERSONALIZZAZIONE CURRENT LOOP INCOTERM 2 Fili

SWITCHES	RICEZIONE PASSIVA
S-01 - S-02 - S-04	OFF
S-05 - S-06 - S-07	OFF
S-09	OFF
S-03 - S-08 - S-10	ON

PERSONALIZZAZIONE PER CURRENT LOOP 4 Fili

SWITCHES	TRANSM. PASS. RECEP. ACTIV.	TRANS. ACTIV. RECEP. PASS.	ALL PASSIVE	ALL ACTIVE
S-01	OFF	OFF	OFF	OFF
S-02	OFF	ON	OFF	ON
S-03	ON	OFF	ON	OFF
S-04	OFF	ON	OFF	ON
S-05	OFF	OFF	OFF	OFF
S-06	OFF	OFF	OFF	OFF
S-07	ON	OFF	OFF	ON
S-08	OFF	ON	ON	OFF
S-09	ON	OFF	OFF	ON
S-10	OFF	OFF	OFF	OFF

6.3.6. POWER ON PROCEDURES

- Set the power supply breaker to "ON"
- The A.C. Voltage supplied to the unit, generates the following D.C. voltages:

- + 8.5V
- 15 V
- + 19 V
- 19 V
- + 5 V
- + 12 V
- 12 V
- 5 V

These voltages power the PWA's which enable the SPPL initialization. This initialization takes place by moving the carriage and the print head to the left till a movement inversion to the right with a halt in the first column is obtained

6.3.7 OFF-LINE TEST PROCEDURE

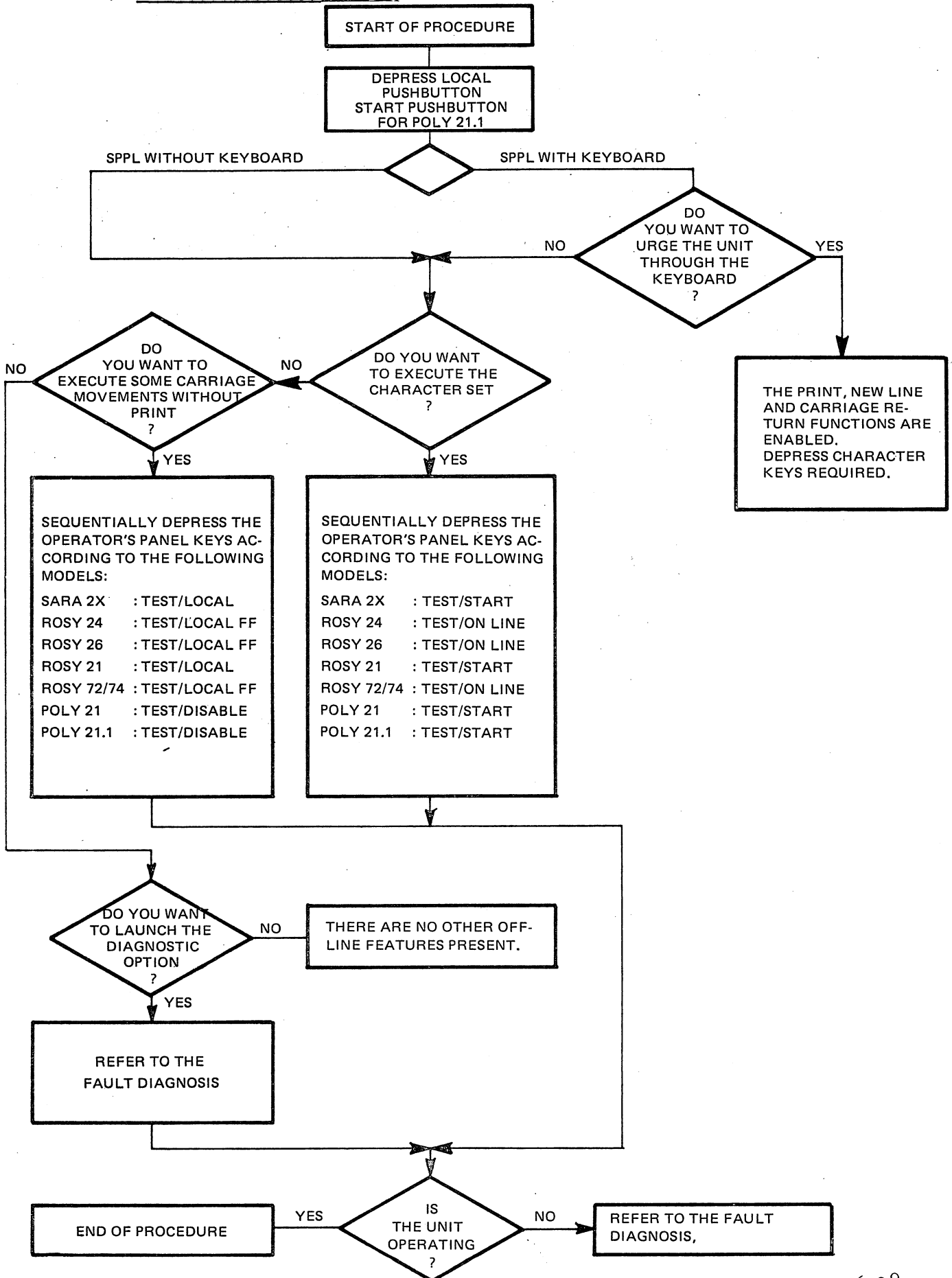

6.3.8 CONNECTION TO HOST

Perform the connection to the Host, through the external interface connector P26, using the cable supplied with the unit.

6.3.9. ON-LINE TEST PROCEDURES

Refer to the system diagnostic procedures to launch the ON-LINE tests ("T & D MANUAL" for connections to I62)

6.3.10 FINAL OPERATIONS

Make sure that all covers have been mounted again.

6.4. DE-INSTALLATION

6.4.1. De-Installation Procedure

- Check that the unit is set to POWER OFF.
- Disconnect the interface cable and withhold it.
- Disconnect the AC cable executing the installation instructions in the reverse order.
- Tighten the MECHANICS/BASE fixing screw (See para. 6.3.2. ITEM 9)
- Halt the carriage movement along the bar (See para. 6.3.2. ITEM B)
- Remove the inked ribbon cartridge
- Remove the keyboard (When the option is present)
- Remove the VPP paperchute (when the option is present)
- The withheld parts and the documentation shall be shipped together with the machine.